

COMPAC®

PRODUCENT SIDEN 1946



* CSC+ sammenlignet med CSC.

**60% MERE
TRYKKRAFT***

COMPAC FJEDERSPÆNDE- PRESSE CSC+

Sikre og effektive løsninger til kraftige fjedre på elbiler, SUV, varebiler, m.m.

Se side 33 for mere information



You
Tube

Søgeord:
Compac CSC+

KATALOG NR. 14



PRODUCENT SIDEN 1946



Sådan skaber Compac værdi

4-7



Donkraft med lav indsats højde 2 ton



Donkraft med lavt chassis 2 ton



Donkraft til varebiler og SUV'er 3 ton



Donkrafte 4 - 15 ton



Højtløftende donkrafte 1,4 - 2 ton



Højtløftende donkrafte 3 - 10 ton



Lufthydrauliske donkrafte



Lufthydrauliske teleskop donkrafte



Hydrauliske oprettersæt



Støttebukke 2 - 12 ton



Hjulløfter til biler, varebiler og SUV'er





Hjulløftere til lastbiler og busser



22-23



Hjulløfter til landbrugs- og entreprenørmaskiner



24-25



Værkstedskraner



26-27



Universale gearkasseløftere

Tilbehør til gearkasseløftere



28-29



Teleskopisk gearkasseløfter til biler, varebiler og SUV'er



30



Teleskopisk gearkasseløfter til lastbiler og busser



31



Fjederspændepresser



32-33



Fodbetjente værkstedspresser 16 - 30 ton



34



Håndbetjente værkstedspresser 20 - 30 ton



35



Fodbetjente værkstedspresser 40 - 50 ton



36



Håndbetjente værkstedspresser 40 - 100 ton



37



Elektro-hydrauliske presser 40 - 100 tons



38-39



Flaskedonkrafte 3 - 50 ton



40

SÅDAN SKABER COMPAC VÆRDI

Lifting is serious business
– We know!

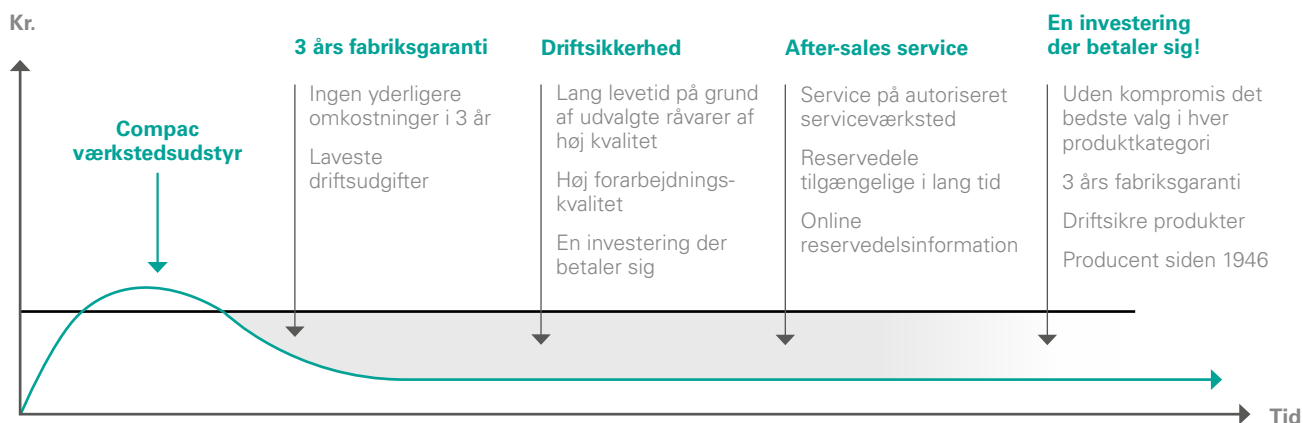

KNOW-HOW ER FORSKELLEN

FABRIKS- GARANTI

Compac satte et benchmark helt tilbage i 2007 ved at være den første producent som tilbyder 3 års garanti.



PRODUCENT SIDEN 1946



HISTORIE

Fire målrettede danskere etablerede Compac i 1946. Deres vision var at fremstille fremragende donkrafte. Denne vision er uændret gennem de seneste mere end 70 år og vi er stolte over at kunne fortsætte vores daglige bestræbelser på at styrke det stærke omdømme for fremragende kvalitet som er opbygget gennem mange år.

KNOW-HOW ER FORSKELLEN



PRODUCENT SIDEN 1946

Compac har produceret hydrauliske produkter i høj kvalitet siden 1946. Målet for vores produktion er at fremstille produkter af høj kvalitet med den primære målsætning at skabe tilfredse kunder.



RESERVEDELE TILGÆNGELIGE I LANG TID

Reserve- og sliddele til Compac produkter er lette at identificere og få fat i. Information om reservedele til alle Compac produkter er let tilgængelig på www.compac.dk og på Compac's App.



ONLINE INFORMATION

Let tilgang til alt reservedelsinformation. Find den rette løsning til jobbet. YouTube film giver en bedre forståelse af bruger fordelene. Reparationsvejledninger med trin-for-trin vejledning, så man oftest kan fejlsøge og reparere produktet på stedet. Betjeningsvejledninger.



RÅVARER I HØJ KVALITET

Compac's hydrauliske komponenter er producerede in-house ved brug af råvarer i høj kvalitet. Vigtige råvarer som hydrauliske cylinderrør, pakninger, ventilblokke, m.m. sources alene fra højkvalitetsleverandører. Der er ingen kompromiser vedrørende kvaliteten af de kritiske råvarer som bruges i fremstillingen af Compac's hydraulik systemer.

UNIKT KVALITETSSYSTEM

Compac opererer med et unikt kvalitetssystem der er inspireret af den Japanske tilgang til kvalitet. Det omfattende kvalitetssystem kombinerer kvalitets-holdningen hos hver enkelt medarbejder med den personlige kvalitetsansvarlighed hos alle der er involverede i produktionsprocessen.



PRODUCENT SIDEN 1946



DONKRAFT MED LAV INDSATSHØJDE 2 TON BILER



Specielle adaptere

til løftepunkter på el- og hybridbiler.



Se side 15 for alle løsningerne.



Idel til løftepunkter langs panel kanter.



Ergonomisk kørestang.

"Løft-og-drej" sænkesystem sikrer imod utilsigtet nedsækning.

Fuldt svejst konstruktion.

Maks. højde 500 mm.

Fodpedal til hurtigt løft til løftepunktet.

Cylinder beskyttet mod skidt, svejseslagger, m.m.

Min. højde 80 mm.

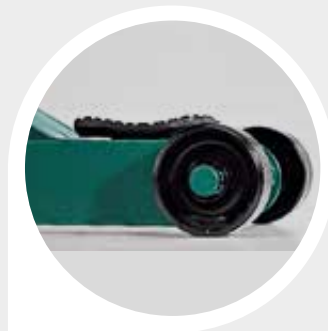

Lavt indstik.

Sikkerhedsventil sikrer kontrolleret nedsænkningshastighed selv under maksimal belastning.

Hydraulisk sikring mod overbelastning.

Støjreducerende nylonhjul.

TILBEHØR



060260
CSL LED smart lys.



1002LF
Gummi saddle beskytter løftepunktet.



003068
Saddle til løft på løftepunkter placeret oppe bag skorter. (+ 40 mm)



2T-C HRW
2T-C monteret med støjsvage hårdgummihjul.



2T-C BOGIE PU
2T-C monteret med bogie system med polyurethan ruller.

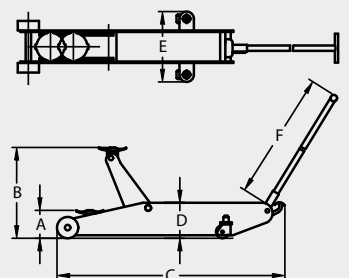

Model	Max (ton)	A (mm)	B (mm)	C (mm)	D (mm)	E (mm)	F (mm)	Kg
2T-C	2	80	500	730	160	380	925	36



DONKRAFT MED LAVT CHASSIS 2 TON BILER



YouTube

Søgeord:
Compac 2T-77



Specielle adaptere
til løftepunkter på
el- og hybridbiler.

Se side 15
for alle løsninger.



Ekstremt lavt chassis forbedrer adgang
under lave køretøjer.



Lavt chassis med lang rækkevidde forbedrer
adgang til løftepunkter dybt under køretøjer.

Fodpedal til
hurtigt løft til
løftepunktet.

Ekstremt lavt chassis,
så donkraften kan
komme under "alle" biler.

Lavt indstik
kun 77 mm.



Meget lavt indstik.

TILBEHØR



060260
CSL LED
smart lys.



1002LF
Gummisaddel beskytter
løftepunktet.



003068
Saddel til løft på
løftepunkter placeret
oppe bag skærter.
(+ 40 mm)



2T-77 HRW
2T-77 monteret med
støjsvage hårdgummihjul.



2T-77 BOGIE PU
2T-77 monteret med bogie
system med polyurethan
ruller.

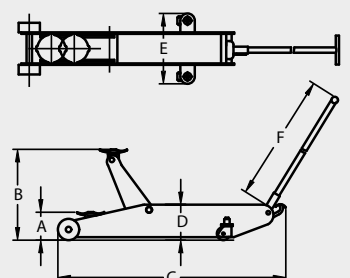

Model	Max (ton)	A (mm)	B (mm)	C (mm)	D (mm)	E (mm)	F (mm)	Kg
2T-77	2	77	480	950	126	380	925	42



DONKRAFT 3 TON

VAREBILER, SUV OG MINIBUSSER



Chassis med lang rækkevidde forbedrer adgang til løftepunkter dybt under køretøjer.



Specielle adaptere til løftepunkter på el- og hybridbiler.

Se side 15 for alle løsningerne.

TILBEHØR



060260
CSL LED smart lys.



1002LF
Gummisaddel beskytter løftepunktet.



003068
Saddel til løft på løftepunkter placeret oppe bag skærter. (+ 40 mm)

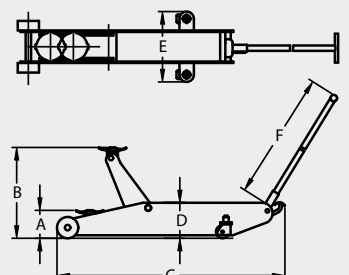

Model	Max (ton)	A (mm)	B (mm)	C (mm)	D (mm)	E (mm)	F (mm)	Kg
3T-C	3	115	500	1015	170	380	925	43



DONKRAFTE 4 - 15 TON LASTBILER OG BUSSE



Lavt chassis med lang rækkevidde forbedrer adgang til løftepunkter dybt under lastbiler. **10T-C med tilbehør 060200**



YouTube

Søgeord:
Compac 10T-C

Ergonomisk kørestang.



Fodpedal til hurtigt løft til løftepunktet.



TILBEHØR



060200
Luftgummihjul kan monteres på balancepunkt, så donkraften bliver markant lettere at manøvrere. Bliver midlertidigt flade under belastning.

Model	Max (ton)	A (mm)	B (mm)	C (mm)	D (mm)	E (mm)	F (mm)	Kg
4T-C	4	130	545	1270	200	465	1045	74
5T-C	5	145	560	1270	200	465	1045	75
6T-C	6	155	570	1395	210	470	1045	97
10T-C	10	165	580	1410	225	435	1045	110
12T-C	12	170	670	1700	280	470	1045	148
15T-C	15	200	600	1790	325	475	1045	169

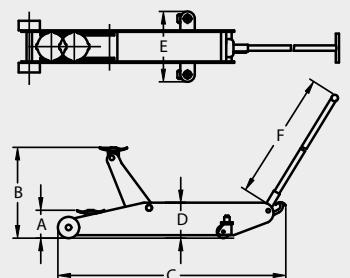



HØJTLØFTENDE DONKRAFTE 1,4 - 2 TON BILER



Maks. højde 715 mm.

1,4T-HC 77

Fodpedal til hurtigt løft til løftepunktet.

Lavt indstik kun 77 mm.

TILBEHØR

060260
CSL LED
smart lys.



Model	Nr.
1,4T-HC 77	001077
2T-HC	1002LF

Gummisaddel beskytter løftepunktet.

Specielle adaptere
til løftepunkter på
el- og hybridbiler.



Se side 15 for alle løsningerne.



1,4T-HC 77 BOGIE PU
2T-HC BOGIE PU
Modeller monteret med bogie system med polyurethan ruller.



1,4T-HC 77 HRW
2T-HC HRW
Modeller monteret med støjsvage hårdgummihjul.

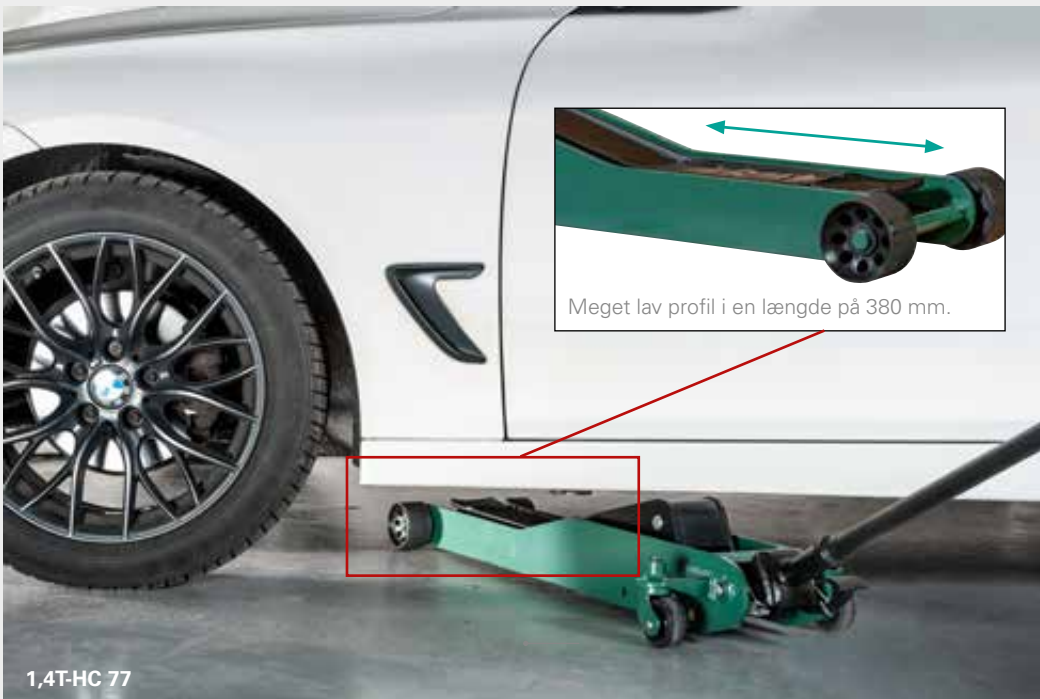

Meget lav profil i en længde på 380 mm.

1,4T-HC 77

Lav profil forbedrer adgang til løftepunkter dybt under de fleste køretøjer.

Sikkerhedsventil sikrer kontrolleret nedsænkningens hastighed selv under maksimal belastning.

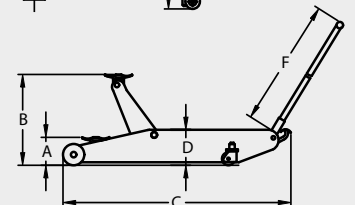
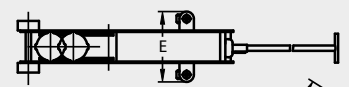

Model	Max (ton)	A (mm)	B (mm)	C (mm)	D (mm)	E (mm)	F (mm)	Kg
1,4T-HC 77	1,4	77	715	1050	190	380	925	52
2T-HC	2	98	735	1035	200	380	1045	56



HØJTLØFTENDE DONKRAFTE 3 - 10 TON

VAREBILER OG LANDBRUGSMASKINER



TILBEHØR



060200
Luftgummihjul kan monteres på balancepunkt, så donkraften bliver markant lettere at manøvrere. Bliver midlertidigt flade under belastning.

8T-HC med tilbehør 060200

Ergonomisk kørestang.

Maks. højde 860 mm.

Maks. højde 960 mm.

“Løft-og-drej” sænkesystem sikrer imod utilsigtet nedsænkning.

Sikkerhedsventil sikrer kontrolleret nedsænkningshastighed selv under maksimal belastning.

Fuldt svejst konstruktion.

Hydraulisk sikring mod overbelastning.

Store drejelige hjul for let manøvrering.



Fodpedal til hurtigt løft til løftepunktet.

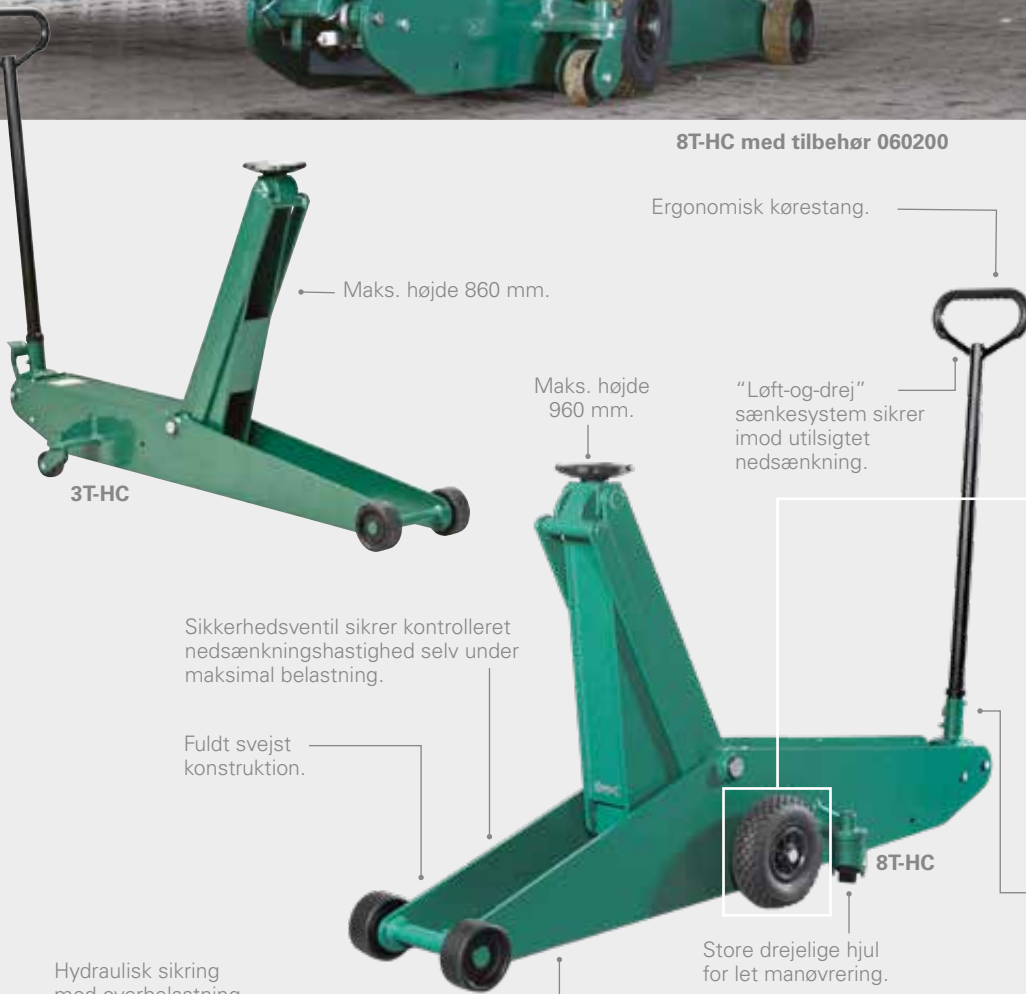

Model	Max (ton)	A (mm)	B (mm)	C (mm)	D (mm)	E (mm)	F (mm)	Kg
3T-HC	3	130	860	1620	210	460	1045	91
6T-HC	6	180	960	1830	350	475	1045	180
8T-HC	8	180	960	1830	350	475	1045	185
10T-HC	10	210	710	1700	290	475	1045	148

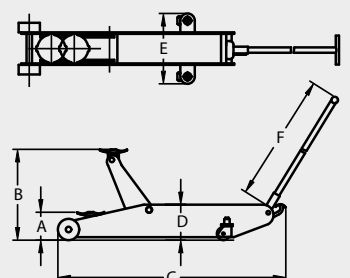



LAV LUFTHYDRAULISK DONKRAFT 1,6 TON BILER



Lavt chassis med lang rækkevidde forbedrer adgang til løftepunkter dybt under køretøjer.

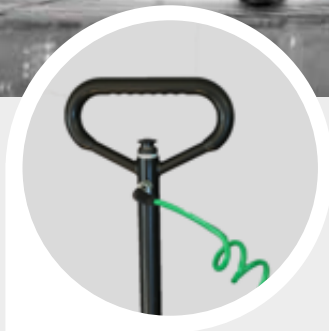

Hurtig og lydløs luftpumpe. Mindre end 70 dB.



Maks. højde 480 mm.



You Tube

Søgeord: Compac A1,6T-77

Ekstremt lavt chassis, så donkraften kan komme under "alle" biler.

Lavt indstik kun 77 mm.



Ekstremt lavt chassis forbedrer adgang under lave køretøjer.



Meget lavt indstik.

TILBEHØR



060260
CSL LED smart lys.



001077
Gummisaddel beskytter løftepunktet.



003068
Saddel til løft på løftepunkter placeret oppe bag skorter. (+ 40 mm)



A1,6T-77 HRW
A1,6T-77 monteret med støjsvage hårdgummihjul.



A1,6T-77 BOGIE PU
A1,6T-77 monteret med bogie system med polyurethan ruller.

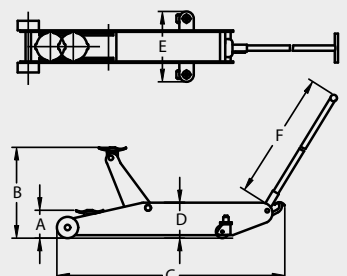

Model	Max (ton)	A (mm)	B (mm)	C (mm)	D (mm)	E (mm)	F (mm)	Kg
A1,6T-77	1,6	77	480	950	126	380	925	44



SPECIELLE ADAPTERE TIL ORIGINALE LØFTEPUNKTER



PASSER TIL LØFTEPUNKTER PÅ EL- OG HYBRIDBILER



Disse adaptore passer til de specielle løftepunkter på de fleste nye bilmodeller fra ovenstående bilproducenter. Adapterne kan placeres på en standard sadel på Compac donkrafte.

Vigtigt: Bemærk at der tilbydes 2 forskellige adaptore til Tesla. Undersøg altid præcist hvilken type Tesla der skal løftes og benyt den rigtige type adapter.



LUFTHYDRAULISKE DONKRAFTE LASTBILER OG BUSSE



A5816-C

LAVE TELESKOPDONKRAFTE

- Sikkerhedsventil sikrer kontrolleret nedsænkning.
- Overtryksventil beskytter mod overbelastning.
- Fjederbelastet nedsænkningssfunktion med dødmandsbetjening.



Søgeord:
Compac A4020-C



Søgeord:
Compac A5816-C

STANDARD

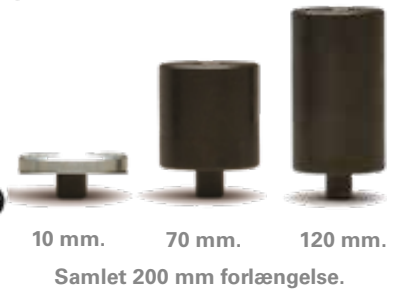

TILBEHØR



0Y1600
Forlængersæt.
3 x 20 mm. 1 x 10 mm.



0Y2618
"V" sadel til løft
på aksler og runde
løftepunkter.



0Y1407
Saddel Ø140.

Model	Max (ton)	A (mm)	B1 (mm)	B2 (mm)	B3 (mm)	B4 (mm)	C (mm)	D (mm)	E (mm)	F (mm)	Kg
A3216-C	32/16	150	220	300	-	500	495	168	310	1230	46
A4020-C	40/20	150	220	300	-	500	495	168	310	1230	46
A5816-C	58/32/16	120	165	210	255	455	665	130	305	1360	57

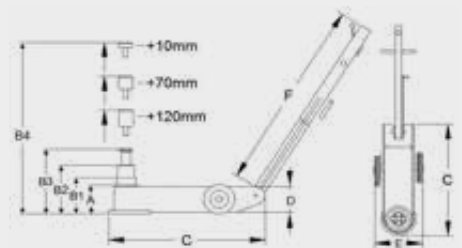



LUFTHYDRAULISKE DONKRAFTE

LASTBILER OG LANDBRUGSMASKINER



A28-HC

EKSTRA HØJ LUFTHYDRAULISK DONKRAFT OG TELESKOPDONKRAFT MED EKSTRA HØJ LØFTEKAPACITET



A28-HC

A4422-C

Model	Max (ton)	A (mm)	B1 (mm)	B2 (mm)	B3 (mm)	B4 (mm)	C (mm)	D (mm)	E (mm)	F (mm)	Kg
A28-HC	28	350	580	-	-	780	735	160	280	1230	64
A4422-C	44/22	220	341	467	-	667	525	168	300	1230	53
A5830-C	58/30	220	330	450	-	650	1050	150	350	1360	80

STANDARD



10 mm. 70 mm. 120 mm.

Samlet 200 mm forlængelse.

TILBEHØR



0Y1600
Forlængersæt.
3 x 20 mm. 1 x 10 mm.



0Y2618
"V" sadel til løft på aksler og runde løftepunkter.



0Y1407
Sadel Ø140.

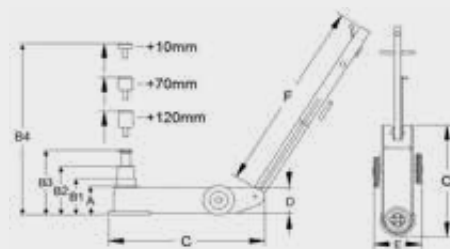



LUFTHYDRAULISK DONKRAFT 10 TON LANDBRUGSMASKINER



HYBRID COMPAC® 10-TONS LUFTHYDRAULISK DONKRAFT



Kørestangen kan låses i 45° for let manøvrering.

Maks. højde 780 mm. **

Standard med luftgummihjul for let manøvrering.

Lav min. højde 150 mm. *

Hurtig og lydløs luftpumpe. Mindre end 70 dB.

STANDARD
Forlænger + 200 mm.



Søgeord:
Compac
A10T-HC



Model	Max (ton)	A (mm)	B (mm)	C (mm)	D (mm)	E (mm)	F (mm)	Kg
A10T-HC	10	150*	780**	1380	225	390	1200	113

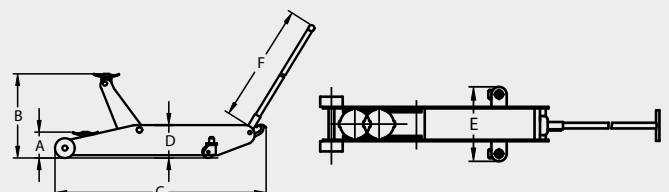

* Uden brug af standard forlænger. / ** Ved brug af standard forlænger



HYDRAULISKE OPRETTERSÆT



Max. kapacitet 4 ton.



17
CRK 4
Vægt: 19 kg.

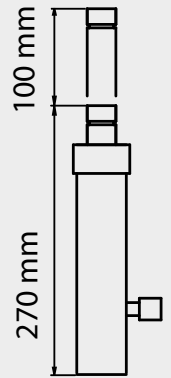

Max. kapacitet 10 ton.



Ideel til løfte, adskille og trykke opgaver. Hydrauliske oprettersæt er ideelle til automotive opretningsværksteder, industrielle anvendelser, m.m.

Lang slaglængde.

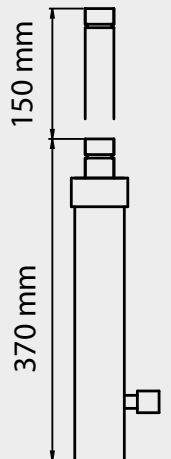

17
CRK 10
Vægt: 36 kg.

	CRK 4	CRK 10
1	Quick-lock adapterstykke, 400 mm.	Quick-lock adapterstykke, 475 mm.
2	Quick-lock adapterstykke, 300 mm.	Quick-lock adapterstykke, 350 mm.
3	Quick-lock adapterstykke, 200 mm.	Quick-lock adapterstykke, 250 mm.
4	Quick-lock adapterstykke, 100 mm.	Quick-lock adapterstykke, 125 mm.
5	"V" adapter.	"V" adapter.
6	Vinkeladapter med gevind.	Vinkeladapter med gevind.
7	Vinkeladapter.	Vinkeladapter.
8	Kileformet adapter.	Kileformet adapter.
9	Fod.	Fod.
10	Saddel.	Saddel.
11	Fleksibel gummiadapter.	Fleksibel gummiadapter.
12	Forbindelsesadapter.	Forbindelsesadapter.
13	Adskillelsesadapter. (Maks. 500 kg.)	Adskillelsesadapter. (Maks. 500 kg.)
14	Cylinder.	Cylinder.
15	Fleksibel tryksslange, 1800 mm.	Fleksibel tryksslange, 1800 mm.
16	4 ton hydraulisk pumpe.	10 ton hydraulisk pumpe.
17	Plastkasse.	Plastkasse med hjul.



ADVARSEL: Pumpens hydrauliske kapacitet overstiger maksimal kapaciteten på adskillelsesadapteren og andre adapterer. Se maksimale kapaciteter ved sammensætning af flere komponenter i instruktionsmanualen.



STØTTEBUKKE 2 - 12 TONS



SOLID KONTRUKTION FOR MAKSIMAL STABILITET OG SIKKERHED

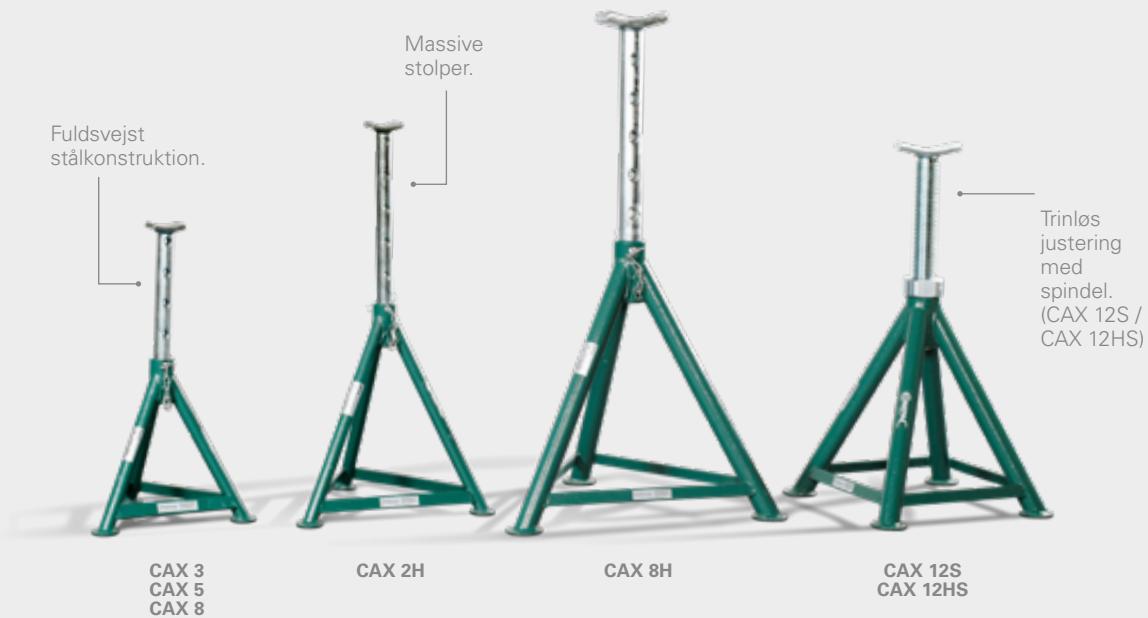

CAX 3
CAX 5
CAX 8

CAX 2H

CAX 8H

CAX 12S
CAX 12HS



Søgeord:
Compac
CAX range

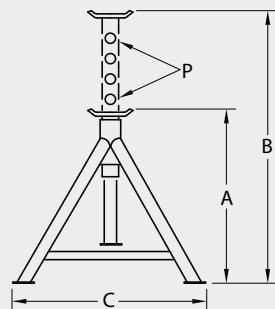

Model	Max (ton)	A (mm)	B (mm)	C (mm)	P	Kg
CAX 2H	2	505	755	491	5	6,6
CAX 3	3	346	510	325	5	4,7
CAX 5	5	406	567	355	5	7,2
CAX 8	8	424	633	403	5	11,5
CAX 8H	8	605	870	575	6	15
CAX 12S	12	345	495	230	Spindel	11,6
CAX 12HS	12	505	740	395	Spindel	14,4



HJULLØFTER

BILER, VAREBILER OG SUV'ER



Hjulets decentrerede placering giver let adgang til hjulbolte.



YouTube

Søgeord:
Compac WD 60

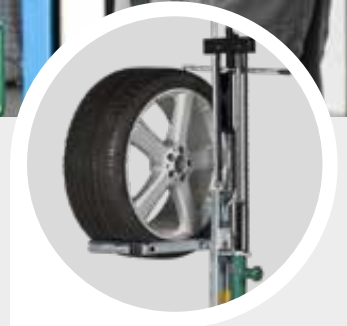

Kapacitet 60 kg. (Udvendig hjuldiameter max. 820 mm.)



Ruller med kuglelejer for let rotation og positionering.



Fodbetjent løftefunktion.



Ingen tunge løft. Hjulløfteren løfter hjulet direkte fra gulvhøjde.



WD 60

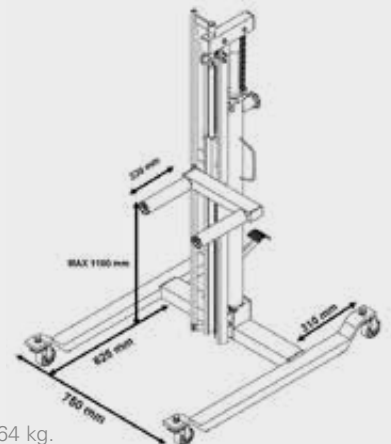

Vægt: 64 kg.



HJULHÅNTERING LASTBILER OG BUSSE



LET OG SIKKER MONTERING, DEMONTERING OG HÅNDBETINGET AF STORE HJUL PÅ VAREBILER, LASTBILER OG BUSSE

WD MOBILE

Det ergonomiske håndtag gør hjulløfteren let at håndtere.

Ekstra hjul for let og sikker manøvrering selv under fuld belastning.

Kapacitet 250 kg.

Ruller med kuglelejer for let rotation og positionering af hjulet.

Vægt: 14 kg.

Kan håndtere meget store lastbilhjul. Eksempelvis 445/65 - 22,5.

Rullerne kan justeres i bredden afhængigt af hjulstørrelsen. Tre positioner i hver side.

Støtteben til hurtig og let parkering uden last.



HJULLØFTER LASTBILER OG BUSSE



WD 500
Kapacitet 500 kg.



Let manøvrering
ved tung last.

Vægt: 101 kg.

Ruller med kuglelejer for
let rotation og positionering.



Fodbetjent løftefunktion.

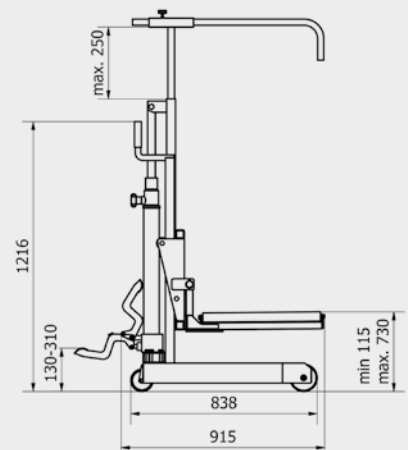
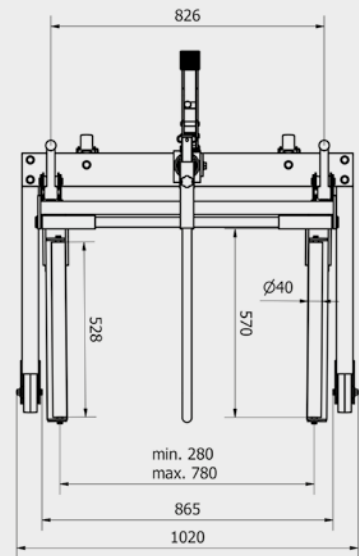

Søgeord:
Compac WD 500



Bærearmer kan indstilles i
bredden for håndtering af
hjul med en udvendig diameter
fra Ø 260 mm - 1320 mm.



EFFEKTIV OG SIKKER MONTERING, DEMONTERING OG HÅNDBLING AF STORE HJUL MED DIAMETER OP TIL 2400 MM





HJULLØFTER

LANDBRUGS- OG ENTREPRENØRMASKINER



Let håndtering af store hjul med diameter fra 1250 mm op til 2400 mm og bredde op til 1050 mm.



2 x 4 store ruller muliggør rotation af hjul med dybe dækmønstre.

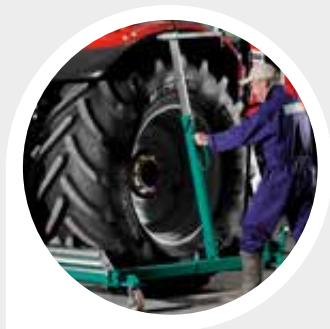

Hydraulikenhedens placering indvendigt i chassiset giver brugeren et stort åbent arbejdsområde.



“Hands-free” fodbetjent omskiftning mellem løfte- og sænkefunktion gør højdejustering let ved montering.

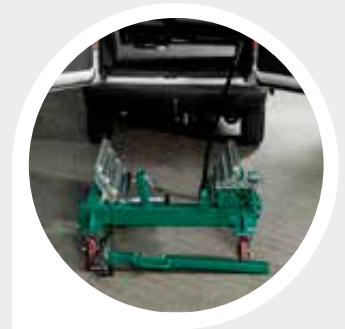

Mobil: Let at bruge uden for værkstedet. Kan skilles ad på få sekunder.



YouTube

Søgeord:
Compac WD 1600

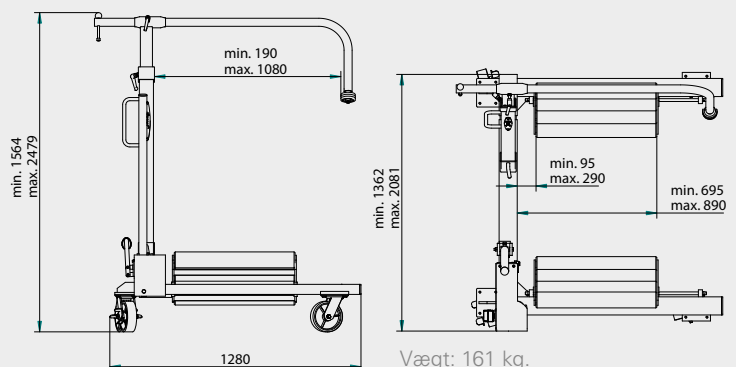



VÆRKSTEDSKRANER BILER



TILBEHØR



939010
Løfteåg.
Kapacitet 500 kg.

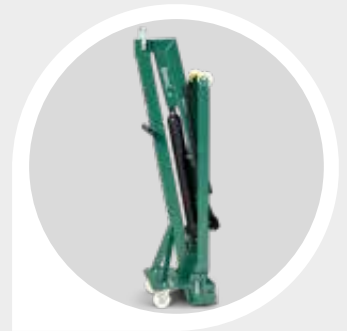

Sammenklappelig.
Pladsbesparende når kranen ikke er i brug. (35x42 cm)

CC 055 kapacitet:

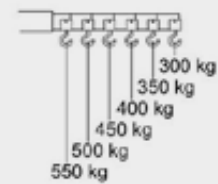

CC 10 kapacitet:

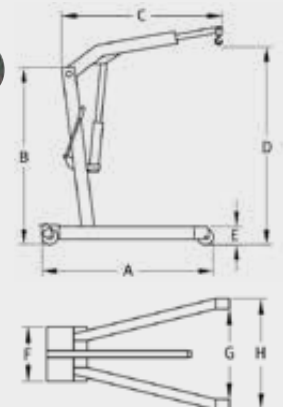
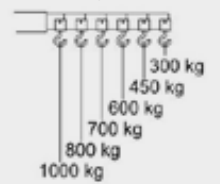

Model	A (mm)	B (mm)	C (mm)	D (mm)	E (mm)	F (mm)	G (mm)	H (mm)	Kg
CC 055	1530	1500	Min. 985 Max. 1435	2120 Max. 550 kg. 2455 Max. 300 kg.	88	440	865	1020	103
CC 10	1530	1500	Min. 985 Max. 1435	2120 Max. 1000 kg. 2455 Max. 300 kg.	88	440	865	1020	103



VÆRKSTEDSKRANER BILER OG INDUSTRIELT BRUG



Den ekstra lange rækkevidde, gør det let at løfte motorer ud af moderne biler.

Svingbar pumpeenhed gør, at kranen kan betjenes fra begge sider.



CC 10

Værkstedskran med høj kapacitet til industrielt brug.

Benene på den industrielle værksteds kran passer rundt om en standard euro palle.



CC 15P

CC 15P kapacitet:

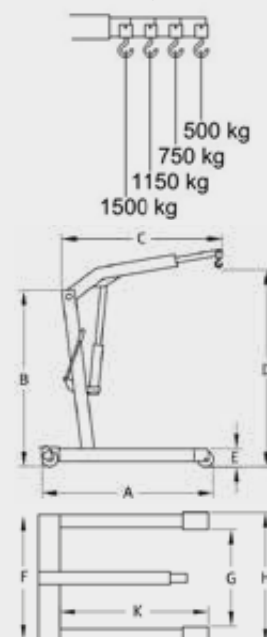

Model	A (mm)	B (mm)	C (mm)	D (mm)	E (mm)	F (mm)	G (mm)	H (mm)	K (mm)	Kg
CC 15P	1720	1860	Min. 1370 Max. 1820	2745 Max. 1500 kg. 3110 Max. 500 kg.	200	1000	850	1015	1570	147



UNIVERSALE GEARKASSELØFTERE BILER OG VAREBILER



Vendbar gearkasseadapter med saddele og gummibelægning.

Ideel til støtte og håndtering af udstødningssystemer, benzintanke, opgaver omkring hjulet, m.m.

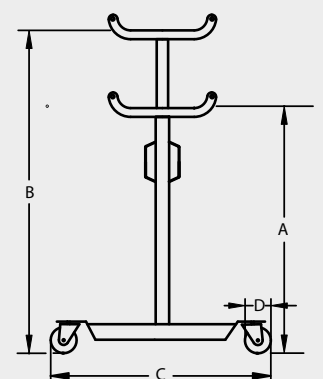
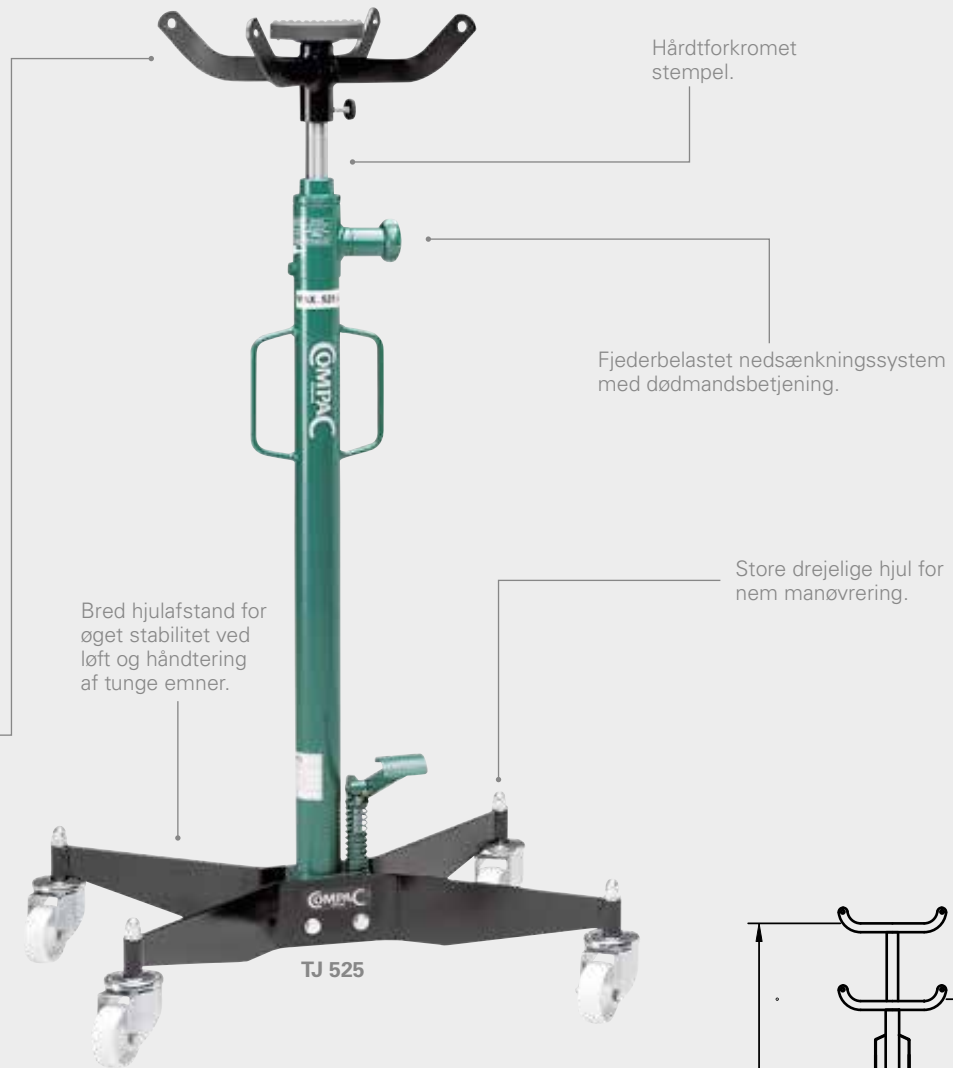

Model	Max (kg)	A (mm)	B (mm)	C (mm)	D (mm)	Kg
TJ 300	300	1095	1930	465 x 565	60	24
TJ 325	325	1170	2020	595 x 535	80	30
TJ 525	525	1170	2020	595 x 535	80	32
TJ 1000	1000	1170	2000	595 x 535	100	38



TILBEHØR TIL GEARKASSELØFTERE BILER OG VAREBILER



053012/053015

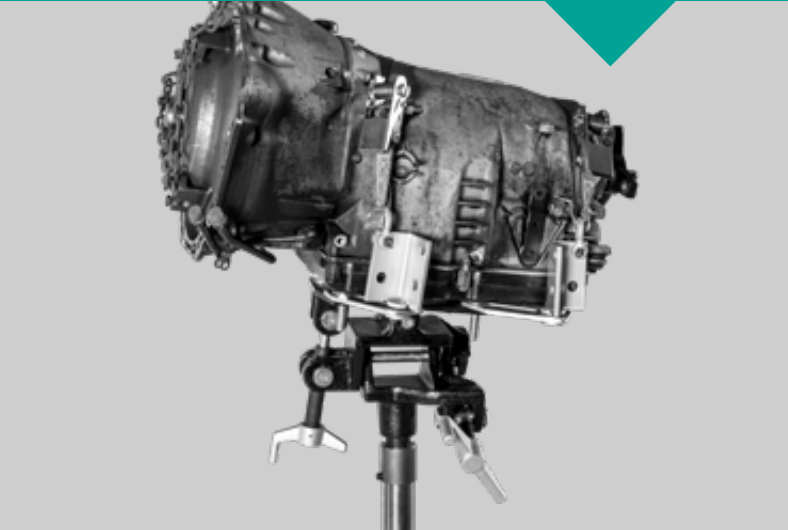

939014

TILBEHØR



Model	Nr.
TJ 300	053012
TJ 325	053012
TJ 525	053012
TJ 1000	053015
TJ-T 1300	053015

McPherson fjederbens støtte.
Bruges til at understøtte og dermed aflaste McPherson fjederben under demontering og montering af bl.a. bærekugler.

Disse arbejdsopgaver er normalt tidskrævende og besværlige, hvis man ikke har muligheden for hurtigt og let at understøtte fjederbenet.



Model	Nr.
TJ 300	053004
TJ 325	053004
TJ 525	053005
TJ 1000	053006
TJ-T 1300	053006

Væskeaftømningsæt inkl. adapter.
Ideel til hurtig og let aftømning af olie, kølevæske, m.m. 18,9 liter.



Model	Nr.
TJ 300	053010
TJ 325	053010
TJ 525	053011
TJ 1000	053013
TJ-T 1300	053013

Adapter.
Adapter uden arme. Forbedrer adgang til områder med begrænset plads.



Model	Nr.
TJ 300	-
TJ 325	-
TJ 525	939014
TJ 1000	939014
TJ-T 1300	939014

Gearkasseværktøj.
Kan justeres i to vinkler for optimal positionering ved håndtering af gearkasser. Kapacitet 300 kg.

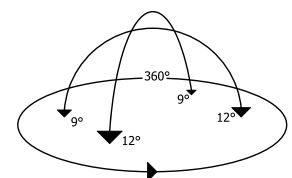



TELESKOPISK GEARKASSELØFTER BILER, VAREBILER OG SUV'ER



939014

TILBEHØR

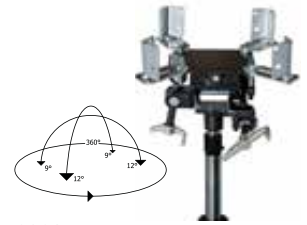

939014
Gearkasseværktøj.
Kan justeres i to vinkler for optimal positionering ved håndtering af gearkasser.

Kapacitet 300 kg.

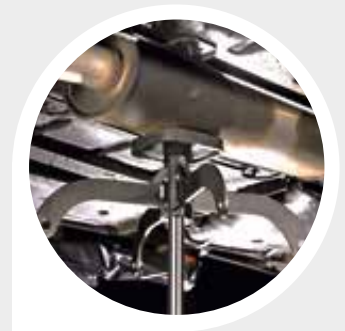

Vendbar gearkasseadapter med sadel og gummibelægning.

Ideal til støtte og håndtering af udstødningssystemer, benzintanke, opgaver omkring hjulet, m.m.

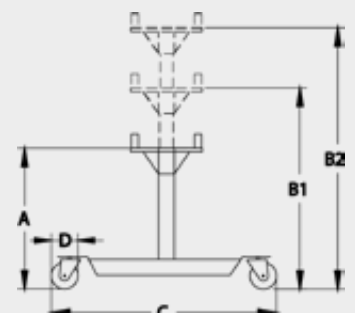

Model	Max (ton)	A (mm)	B1 (mm)	B2 (mm)	C (mm)	D (mm)	Kg
TJ-T 1300	1.3 / 0.5	1000	1500	2010	760 x 640	100	65



TELESKOPISK GEARCASSELØFTER LASTBILER OG BUSSE



TILBEHØR

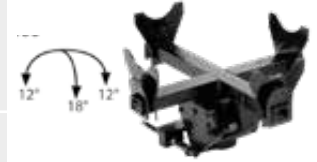

939007

Gearkasseværktøj kan justeres for optimal positionering og sikker håndtering af gearkasser.

Kapacitet 1000 kg.

Tre-trins cylinder for ekstra lav minimumshøjde og lang slaglængde.

Hårdtforchromet stempel.

To-trins pumpe for hurtig fremføring af stempel til emnet.

Store drejelige hjul for nem manøvrering.



TJ-T 2000

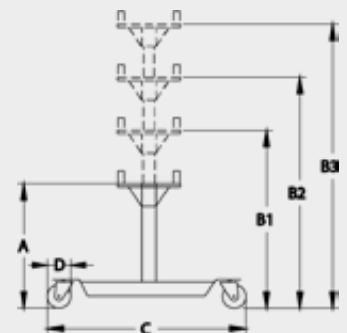

Model	Max (ton)	A (mm)	B1 (mm)	B2 (mm)	B2 (mm)	C (mm)	D (mm)	Kg
TJ-T 2000	2.0 / 1.0 / 1.0	960	1320	1600	1910	1050 x 1050	150	106



FJEDERSPÆNDEPRESSE BILER



EFFEKTIV OG SIKKER MONTERING OG DEMONTERING AF MCPHERSON FJEDERBENSYSYSTEMER.

Model						
CSC	✓	✓	✓			

Anbefales til små og mellemstore biler.



YouTube

Søgeord:
Compac CSC

STANDARD



2 stk. universale fjederbakker
(Ø78 - 125 mm og Ø125 - 200 mm)



Sikkerhedsgitter.

TILBEHØR



929050
Universal skruestik til McPherson fjederben.



McPherson fjederben monteret i struestikken.

SPECIAL VÆRKTØJ

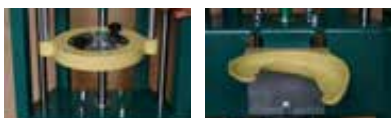

929052
Adapter til Mercedes A, B, C og E-klasse. (C-klasse op til og med 2009)



929059
Adapter til Mercedes C-klasse fra 2010 og nyere.



929051
Fjederbakke Ø105 - 182 mm. Anbefales bla. til: Renault Megane, Renault Clio, Citroën C3, Citroën C4, Peugeot 208, Peugeot 308, Fiat 500, Toyota Yaris, VW Polo, VW Golf. (Lerevæs med i Mercedes kit 929052)



FJEDERSPÆNDEPRESSE

BILER, EL-BILER OG VAREBILER



Model						
CSC+	✓	✓	✓	✓	✓	✓

Anbefales til små-, mellemstørrelse- og store biler. Plus elbiler, SUV og varebiler.



YouTube

Søgeord:
Compac CSC+

60% MERE TRYKKRAFT*



Ekstra stærke arme monteret med teflon glidelejer.

Sikkerhedsgitterets design sikrer ergonomisk rigtig arbejdsposition.



Hårdtforchromede, solide søjler.

Universelle svingbare fjederholdere passer til "alle" fjedre. Maksimal afstand imellem fjederholdere helt op til 420 mm.



Stor Ø160 mm luftcylinder for ekstra trykkraft.

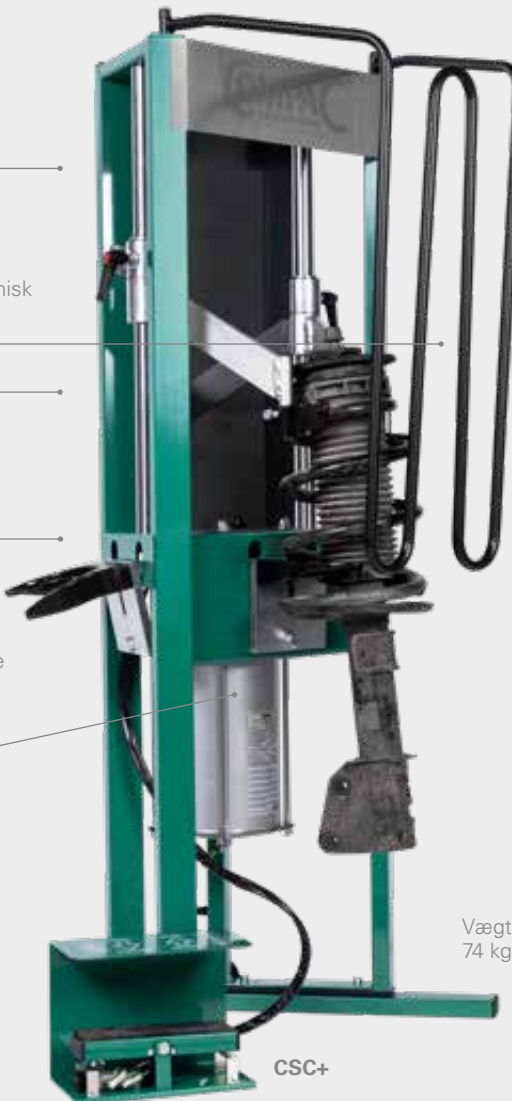

Vægt: 74 kg.

CSC+

STANDARD



2 stk. universale fjederbakker (Ø78 - 125 mm og Ø125 - 200 mm)

Sikkerhedsgitter.

TILBEHØR



929050 Universal skruestik til McPherson fjederben.



McPherson fjederben monteret i struestikken.



929063 Justerbar fjederbensstøtte.



929053 Fjederholder med lave læber.



929060 Adapter til Renault Koleos, Renault Kadjar, Nissan Qashqai, Nissan Juke.



929057 Skruestik til Chrysler Voyager og Mercedes.



929062 Vinkeljusterbare fjederholdere. Ideelle til venstre vendte vindinger (Renault/Nissan) og kraftige fjedre på varebiler. Tilpasser sig dynamisk under komprimering.



FODBETJENTE VÆRKSTEDSPRESSER 16 - 30 TON BILER OG VAREBILER



Flytbar cylinder.

TILBEHØR



FP 30: Standard med spil til hurtig og let justering af bordhøjde.

FP 25 med spil: Bestil model FP 25 W.
FP 20 med spil: Bestil model FP 20 W.
FP 16 fås ikke med spil.
Spil kan **IKKE** eftermonteres!



Hurtig, fodbetjent trykluftstyret fremføring af stempel.
(FP 20/FP 25/FP 30)

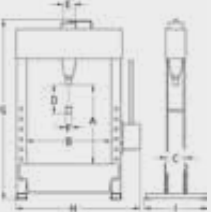

Søgeord:
Compac FP 30

Hårdtforchromet stempel.

Lang slaglængde på 240 mm.
(FP 20/FP 25/FP 30)

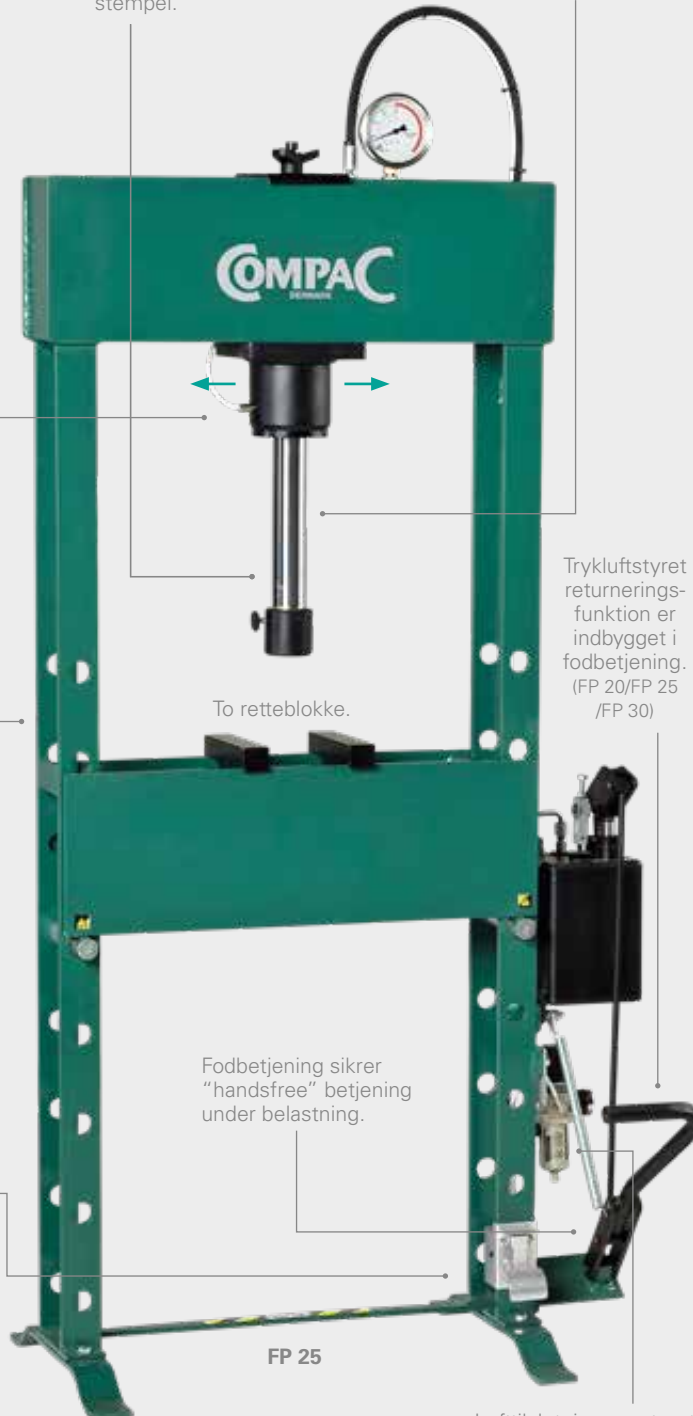

To retteblokke.

Fodbetjening sikrer "handsfree" betjening under belastning.

Trykluftstyret returneringsfunktion er indbygget i fodbetjening.
(FP 20/FP 25 /FP 30)

Lufttilslutning monteret med vandudskiller.
(FP 20/FP 25/FP 30)

TILBEHØR



061248
Lejeopsætningsværktøj.



061100
Presseplade.



061240
Hyldesystem til opbevaring af tilbehør.



Model	Nr.
FP 16	061219
FP 20	061216
FP 25	061216
FP 30	061216

Domsæt.
7 stk. Ø12, 16, 18, 20, 22, 25, 30.



Model	Nr.
FP 16	061220
FP 20	061218
FP 25	061218
FP 30	061218

Lejudpresningsæt.
4 stk. Ø64, 67, 72, 75.



061242
Beskyttelsesskærm.

Model	Max (ton)	(mm/stroke)	A (mm)	B (mm)	C (mm)	D (mm)	E (mm)	F (mm)	G (mm)	H (mm)	I (mm)	Kg
FP 16	16	6,0/2,0	1200	550	140	150	65	40	1780	850	600	121
FP 20	20	9,0/1,1	825	600	140	240	90	70	1800	890	505	157
FP 25	25	9,0/1,1	825	600	140	240	90	70	1800	890	505	157
FP 30	30	9,0/1,1	825	600	140	240	90	70	1800	890	505	160



HÅNDBETJENTE VÆRKSTEDSPRESSER 20 - 30 TON BILER OG VAREBILER



Flytbar cylinder.

TILBEHØR



HP 30: Standard med spil til hurtig og let justering af bordhøjde.

HP 25 med spil: Bestil model HP 25 W.
HP 20 med spil: Bestil model HP 20 W.
HP 16 fås ikke med spil.
Spil kan **IKKE** eftermonteres!

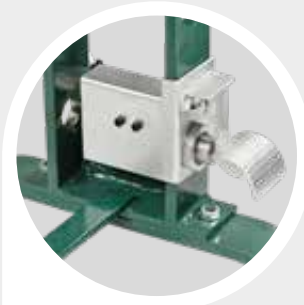

Hurtig, fodbetjent trykluftstyret fremføring af stempel.

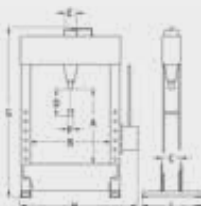

Hårdforkromet stempel.

Lang slaglængde på 240 mm.

Luftstyret returneringsfunktion er indbygget i pumpehåndtaget.



To retteblokke.

HP 25

Lufttilslutning monteret med vandudskillere.

TILBEHØR



061248
Lejeopsætningsværktøj.



061100.
Presseplade.

061240
Hylde-system til opbevaring af tilbehør.



Model	Nr.
HP 20	061216
HP 25	061216
HP 30	061216

Dornsæt.
7 stk. Ø12, 16, 18, 20, 22, 25, 30.



Model	Nr.
HP 20	061218
HP 25	061218
HP 30	061218

Lejeudpresningsæt.
4 stk. Ø64, 67, 72, 75.



061242
Beskyttelsesskærm.

Model	Max (ton)	(mm/stroke)	A (mm)	B (mm)	C (mm)	D (mm)	E (mm)	F (mm)	G (mm)	H (mm)	I (mm)	Kg
HP 20	20	9,0/4,0	825	600	140	240	90	70	1800	890	505	156
HP 25	25	9,0/4,0	825	600	140	240	90	70	1800	890	505	156
HP 30	25	9,0/4,0	825	600	140	240	90	70	1800	890	505	159



FODBETJENTE VÆRKSTEDSPRESSER 40 - 50 TON LASTBILER OG BUSSE



TILBEHØR



061248
Lejeopsætningsværktøj.

Model	Nr.
FP 40	061248
FP 50	061248



Spil med automatisk bremse til hurtig og let justering af bordhøjde.



Hurtig, fodbetjent trykluftstyret fremføring af stempel.

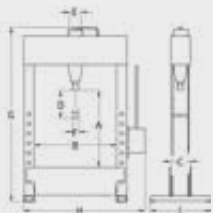

YouTube Søgeord:
Compac FP 50

Fodbetjening sikrer "handsfree" betjening under belastning.

TILBEHØR



061100
Presseplade.



061240
Hylde system til opbevaring af tilbehør.



Model	Nr.
FP 40	061216
FP 50	061216

Dornsæt.
7 stk. Ø12, 16, 18, 20, 22, 25, 30.



Model	Nr.
FP 40	061218
FP 50	061218

Lejeudpresningsæt.
4 stk. Ø64, 67, 72, 75.



Model	Nr.
FP 40	061243
FP 50	061243

Beskyttelseskærm.

Model	Max (ton)	(mm/stroke)	A (mm)	B (mm)	C (mm)	D (mm)	E (mm)	F (mm)	G (mm)	H (mm)	I (mm)	Kg
FP 40	40	6,0/0,8	750	840	200	300	125	70	1990	1350	630	375
FP 50	50	6,0/0,8	750	840	200	300	125	70	1990	1350	630	375



HÅNDBETJENTE VÆRKSTEDSPRESSER 40 - 100 TON LASTBILER OG BUSSE



TILBEHØR



061248
Lejeopsætningsværktøj.

Model	Nr.
HP 40	061248
HP 50	061248
HP 60	-
HP 70	-
HP 100	-



Spil med automatisk bremse til hurtig og let justering af bordhøjde.



Hurtig, fodbetjent trykluftstyret fremføring af stempel.



TILBEHØR



061100
Presseplade.



061240
Hyldesystem til opbevaring af tilbehør.



Model	Nr.
HP 40	061216
HP 50	061216
HP 60	061228
HP 70	061228
HP 100	061233

Dornsæt.
7 stk. Ø12, 16, 18, 20, 22, 25, 30.



Model	Nr.
HP 40	061218
HP 50	061218
HP 60	061229
HP 70	061229
HP 100	061234

Lejeudpresningssæt.
4 stk. Ø64, 67, 72, 75.



Model	Nr.
HP 40	061243
HP 50	061243
HP 60	061245
HP 70	061245
HP 100	061247

Beskyttelseskærm.

Model	Max (ton)	(mm/stroke)	A (mm)	B (mm)	C (mm)	D (mm)	E (mm)	F (mm)	G (mm)	H (mm)	I (mm)	Kg
HP 40	40	6,0/1,5	750	840	200	300	125	70	1990	1350	630	374
HP 50	50	6,0/1,5	750	840	200	300	125	70	1990	1350	630	374
HP 60	60	5,0/0,8	760	1005	255	300	160	80	2100	1615	710	690
HP 70	70	5,0/0,8	760	1005	255	300	160	80	2100	1615	710	690
HP 100	100	3,4/0,8	915	1035	305	300	200	100	2200	1637	800	946



ELEKTRO-HYDRAULISKE VÆRKSTEDSPRESSER 40 - 60 TON ENKELTVIRKENDE CYLINDER



TILBEHØR



061248
Lejeopsætningsværktøj.

Model	Nr.
EP 40	061248
EP 60	-

≡ **Enkeltvirkende cylinder:**
Cylinder uden trækraft. Anbefales kun ved presseopgaver hvor montering af værktøjer ikke kræves.



Spil med automatisk bremse til hurtig og let justering af bordhøjde.



Pumpeenheden kan svinges 90 grader væk fra pressen.

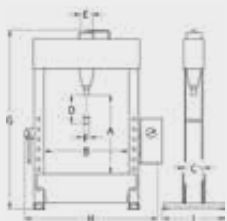

TILBEHØR



061100
Presseplade.



061240
Hyldesystem til opbevaring af tilbehør.



Model	Nr.
EP 40	061216
EP 60	061228

Dornsæt.
7 stk. Ø12, 16, 18, 20, 22, 25, 30.



Model	Nr.
EP 40	061218
EP 60	061229

Lejeudpresningssæt.
4 stk. Ø64, 67, 72, 75.



Model	Nr.
EP 40	061243
EP 60	061245

Beskyttelseskærm.

Model	Max (ton)	(mm/stroke)	A (mm)	B (mm)	C (mm)	D (mm)	E (mm)	F (mm)	G (mm)	H (mm)	I (mm)	Kg	Kw
EP 40	40	10,0	750	840	200	300	125	70	1990	1480	630	390	2,2
EP 60	60	10,0/5,0	760	1000	255	300	160	80	2100	1680	710	694	2,2



ELEKTRO-HYDRAULISKE VÆRKSTEDSPRESSER 40 - 100 TON DOBBELTVIRKENDE CYLINDER



TILBEHØR



061248
Lejeopsætningsværktøj.

Model	Nr.
EP 40 D	061248
EP 60 D	-
EP 100 D	-



Spil med automatisk bremse til hurtig og let justering af bordhøjde.



Pumpeenheden kan svinges 90 grader væk fra pressen.



Dobbeltvirkende cylinder:

Cylinder med både tryk- og trækraft. Anbefales ved presseopgaver hvor montering af værktøj kræves.



EP 40 D

Model	Max (ton)	(mm/stroke)	A (mm)	B (mm)	C (mm)	D (mm)	E (mm)	F (mm)	G (mm)	H (mm)	I (mm)	Kg	Kw
EP 40 D	40	10,0	750	840	200	300	125	70	1990	1480	630	396	2,2
EP 60 D	60	10,0/5,0	760	1000	255	300	160	80	2100	1680	710	702	2,2
EP 100 D	100	10,0/1,4	915	1035	305	300	200	100	2200	1780	800	981	2,2

TILBEHØR



061100
Presseplade.

061240
Hyldesystem til opbevaring af tilbehør.



Model	Nr.
EP 40 D	061216
EP 60 D	061228
EP 100 D	061233

Domsæt.
7 stk. Ø12, 16, 18, 20, 22, 25, 30.



Model	Nr.
EP 40 D	061218
EP 60 D	061229
EP 100 D	061234

Lejeudpressingssæt.
4 stk. Ø64, 67, 72, 75.



Model	Nr.
EP 40 D	061243
EP 60 D	061245
EP 100 D	061247

Beskyttelseskærm.



FLASKEDONKRAFTE 3 - 50 TON



SHARK&CO

FLASKEDONKRAFTE

- Højdejusterbare sadler (3-20 tons)
- Bærehåndtag (10-50 tons modeller)
- Hydraulisk sikring mod overbelastning.

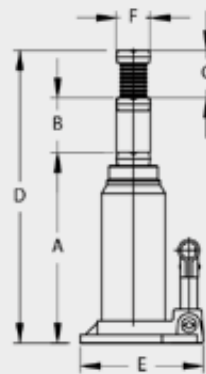

Model	Max (ton)	A (mm)	B (mm)	C (mm)	D (mm)	E (mm)	F (mm)	Kg
CBJ 3	3	193	120	60	373	110x103	26	3
CBJ 5	5	210	136	70	416	122x115	30	3,9
CBJ 10	10	230	150	80	460	132x120	36	5,6
CBJ 15	15	230	150	60	440	144x134	43	7,2
CBJ 20	20	242	150	60	452	159x143	46	9,2
CBJ 30	30	275	165	-	440	169x153	49	11,9
CBJ 50	50	265	160	-	425	210x176	83	25,8
CBJ-T 10	10	215	247	78	540	150x145	37	9,3

Compac forbeholder sig ret til at lade produkter udgå, ændre priser og levere produkter der er forskellige fra illustrationer og specifikationer.

Compac Hydraulik A/S

Strandhusevej 43 // 7130 Juelsminde // Danmark // Tel: +45 75 69 37 22 // info@compac.dk
www.compac.dk